



Sound That Will Move You

DBXi Subwoofer Installation & Reference Manual

DBXi Subwoofers

**DBXI-10
DBXI-10D
DBXI-12
DBXI-12D
DBXI-15
DBXI-15D**



www.earthquakesound.com

Earthquake Sound Corporation • 2727 McCone Avenue Hayward, CA 94545 • Ph: (510) 732-1000 Fax (510) 732-1095

EARTHQUAKE SOUND 5-YEAR LIMITED WARRANTY

Five (5) year limited warranty

Earthquake warrants the original purchaser that all Factory Sealed New Audio Products to be free from defects in material and workmanship under normal and proper use for a period of five (5) years from the date of purchase (as shown on the original bill of sale with serial number affixed/written on it). The five (5) year warranty period is valid only if an authorized Earthquake dealer properly installs the product and the warranty registration card is properly filled out and sent to Earthquake Sound Corporation. If a non-authorized party installs the product, a ninety (90) day warranty period will be applied.

(A) Five (5) years limited warranty plan coverage guidelines:

- **First year:** Earthquake pays for labor, parts, and ground freight (only in US mainland, not including Alaska and Hawaii) (shipping to us is not covered).
- **Second year:** Earthquake pays for labor and parts only, customer must pay freight both ways.
- **Third, fourth & fifth year:** Earthquake pays labor only. Customer must pay for parts and freight both ways.

(B) Warning:

Products (sent for repair) that are tested by Earthquake technicians and deemed to have no problem(s) will not be covered by the five (5) year limited warranty. Customer will be charged a minimum of one (1) hour of labor (at the ongoing rates) plus shipping charges back to customer.

(C) Earthquake will repair or replace - at our option - all defective products/parts subject to the following provisions:

- Defective products/parts have not been altered or repaired by other than an Earthquake factory-approved technician.
- Products/parts are not subjected to negligence, misuse, improper use or accident, damaged by improper line voltage, used with incompatible products or have its serial number or any part of it altered, defaced or removed, or have been used in any way that is contrary to Earthquake's written instructions.

(D) Warranty Limitations:

Warranty does not cover products that have been modified or abused, including but not limited to the following:

- Damages to speaker cabinet and cabinet finish due to misuse, abuse or improper use of cleaning materials/methods.
- Bent speaker frame, broken speaker connectors, holes in speaker cone,

surround & dust cap, burnt speaker voice coil.

- Fading and or deterioration of speaker components & finish due to improper exposure to elements.
- Bent amplifier casing, damaged finish on the casing due to abuse, misuse or improper use of cleaning material.
- Burnt tracers on PCB.
- Product/part damaged due to poor packaging or abusive shipping conditions.
- Subsequent damage to other products.

A warranty claim will not be valid if the warranty registration card is not properly filled & returned to Earthquake with a copy of the sales invoice. Warranty card is located on the last page of this manual.

(E) Service Request:

To receive product service, contact Earthquake service department at (510) 732-1000 and request an RMA number (Return Material Authorization). Items shipped without a valid RMA number will be refused. Make sure you provide us with your complete/correct shipping address, a valid phone number, and a brief description of the problem you are experiencing with the product. In most cases, our technicians might be able to resolve the problem over the phone; thus, eliminating the need to ship the product.

(F) Shipping Instructions:

Product(s) must be packaged in its original protective box(es) to minimize transport damage. Shipper claims regarding items damaged in transit must be presented to carrier. Earthquake Sound Corporation reserves the right to refuse improperly packed product. Original bill of sale must accompany product returned for service. We encourage you to include with the package a written description of the problem. Ship product to: Earthquake Sound Corp. 2727 Mc Cone Avenue, Hayward, CA 94545. Ph (510) 732-1000. You are responsible for the cost of shipping the product to Earthquake Sound Corporation.

(G) Disputes Resolution:

All disputes - between clients and Earthquake Sound Corporation - resulting from the five (5) years limited warranty policy must be resolved according to the laws & regulations of the county of Alameda -California.

PRODUCT REGISTRATION

Your subwoofer(s) be registered by returning the Product Registration card attached to this manual or by visiting www.earthquakesound.com/form_reg.htm. Please also retain the bill of sale, which represents proof of purchase and helps expedite warranty issues.

We recommend that you place or write your serial number here for future reference, if necessary.

SERIAL NUMBER

PARALLEL WIRING

According to Ohm laws, when speakers are wired in parallel. The formula is:

$$\frac{1}{R} = \frac{1}{R1} + \frac{1}{R2} + \frac{1}{R3} + \dots + \frac{1}{Rn}$$
 Where R= Total system impedance

Series formula:

$$Rt = R1 + R2 + R3 + \dots$$
 Where Rt= Resistance seen by amplifier

Study sample diagram below, then follow charts to the left.

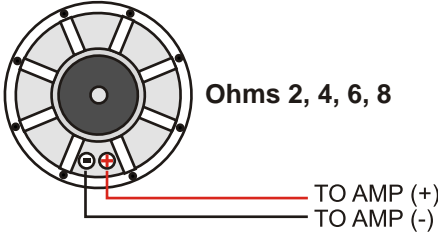

Ohms 2, 4, 6, 8

TO AMP (+)
TO AMP (-)

If using SINGLE 2 OHM coils the total load would be 2.0 ohm
 If using SINGLE 4 OHM coils the total load would be 4.0 ohm
 If using SINGLE 6 OHM coils the total load would be 6.0 ohm
 If using SINGLE 8 OHM coils the total load would be 8.0 ohm

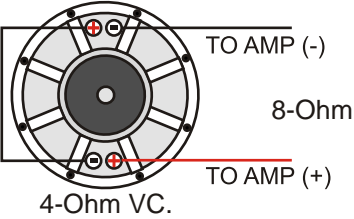

4-Ohm VC.
TO AMP (-)
8-Ohm
TO AMP (+)
4-Ohm VC.

Example for Dual-4 series

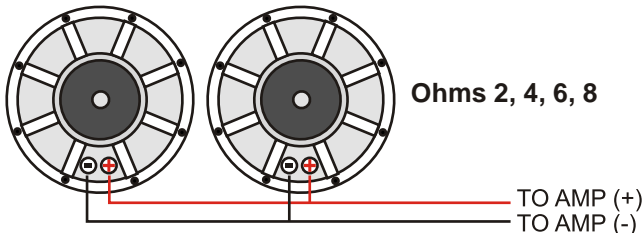

Ohms 2, 4, 6, 8

TO AMP (+)
TO AMP (-)

If using SINGLE 2 OHM coils the total load would be 1.0 ohm
 If using SINGLE 4 OHM coils the total load would be 2.0 ohm
 If using SINGLE 6 OHM coils the total load would be 3.0 ohm
 If using SINGLE 8 OHM coils the total load would be 4.0 ohm

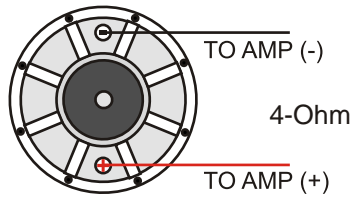

TO AMP (-)
4-Ohm
TO AMP (+)

Example for single-4

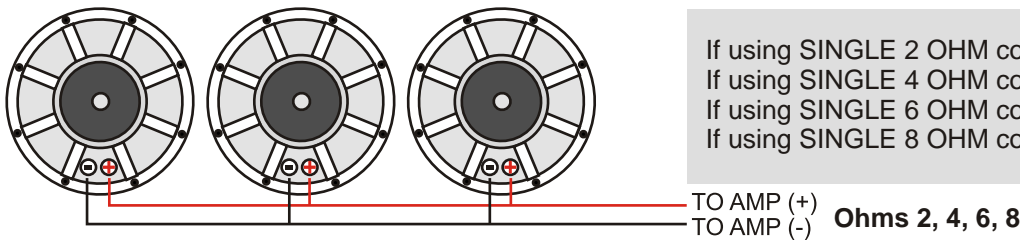

Ohms 2, 4, 6, 8

TO AMP (+)
TO AMP (-)

If using SINGLE 2 OHM coils the total load would be .66 ohm
 If using SINGLE 4 OHM coils the total load would be 1.3 ohm
 If using SINGLE 6 OHM coils the total load would be 2 ohm
 If using SINGLE 8 OHM coils the total load would be 2.7 ohm

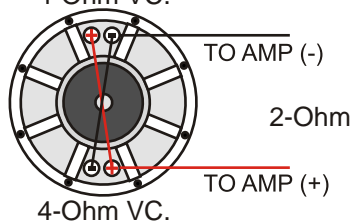

4-Ohm VC.
TO AMP (-)
2-Ohm
TO AMP (+)
4-Ohm VC.

Example Dual-4 Parallel

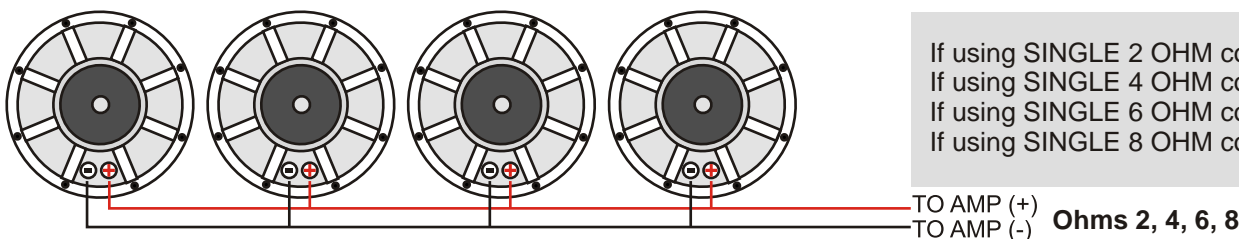

Ohms 2, 4, 6, 8

TO AMP (+)
TO AMP (-)

If using SINGLE 2 OHM coils the total load would be 0.5 ohm
 If using SINGLE 4 OHM coils the total load would be 1.0 ohm
 If using SINGLE 6 OHM coils the total load would be 1.5 ohm
 If using SINGLE 8 OHM coils the total load would be 2 ohm

DBXI ENCLOSURE DESIGNS

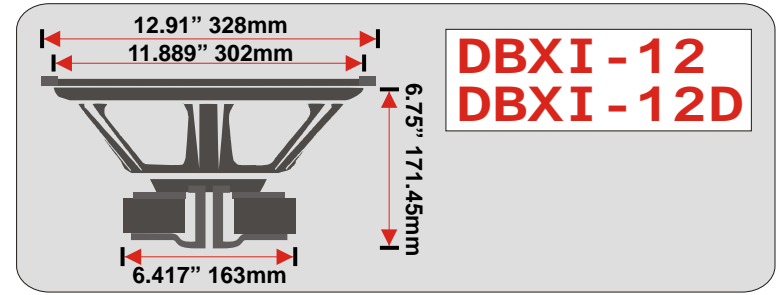
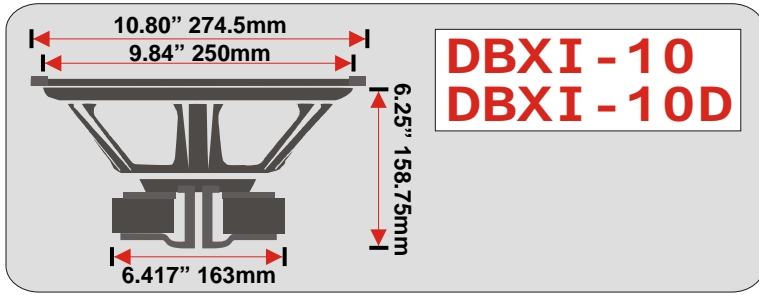

Dimensions shown are external .75" MDF.

DBXI-10/10D

#1 Bass head design for competition
Ported box Recommendation: 1.14-1.5cu.ft.

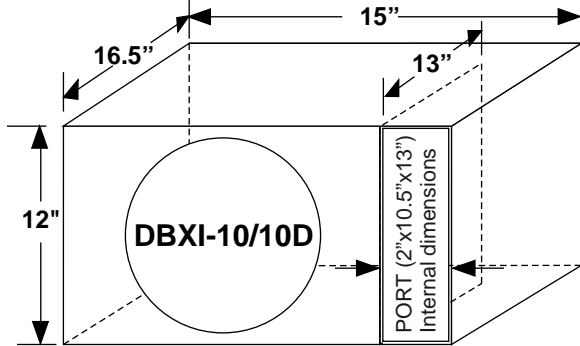

#2 Port tuned design for deep bass
Ported box Recommendation: .8-1.25cu.ft.

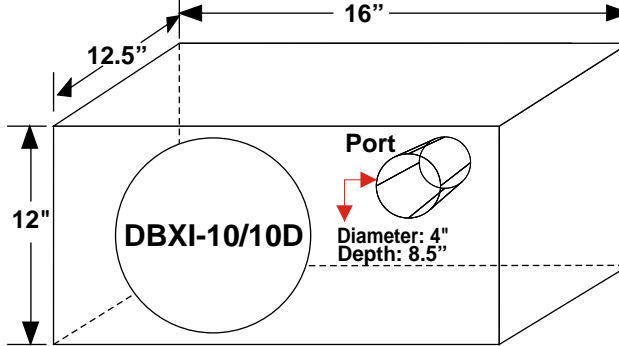

#3 Sealed design for tight bass
Sealed box Recommendation: .77-1.0cu.ft.

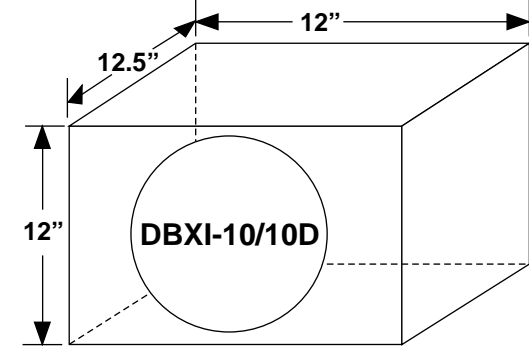

DBXI-12/12D

#1 Bass head design for competition
Ported box Recommendation: 1.8-2.5cu.ft.

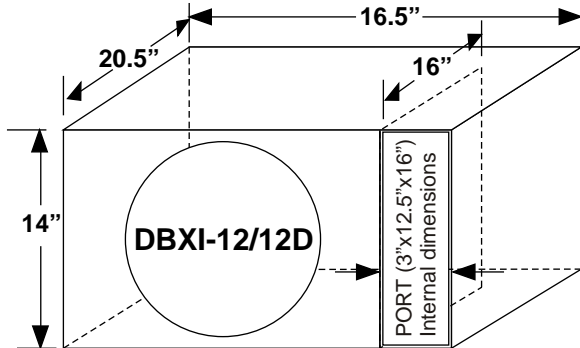

#2 Port tuned design for deep bass
Ported box Recommendation: 1.5-1.75cu.ft.

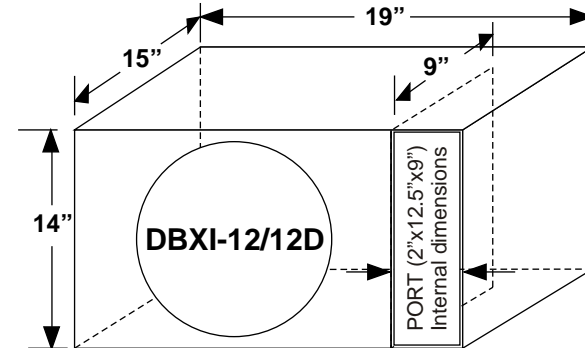

#3 Sealed design for tight bass
Sealed box Recommendation: .9-1.25cu.ft.

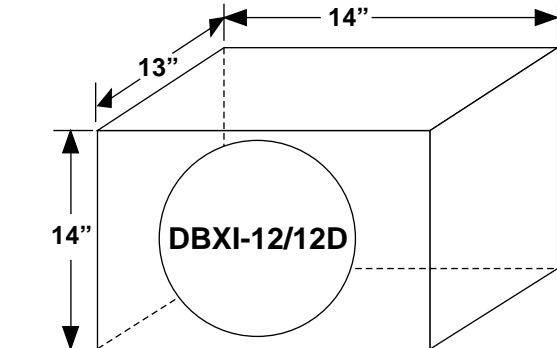

Specifications are subject to change without notice.

DBXI ENCLOSURE DESIGNS

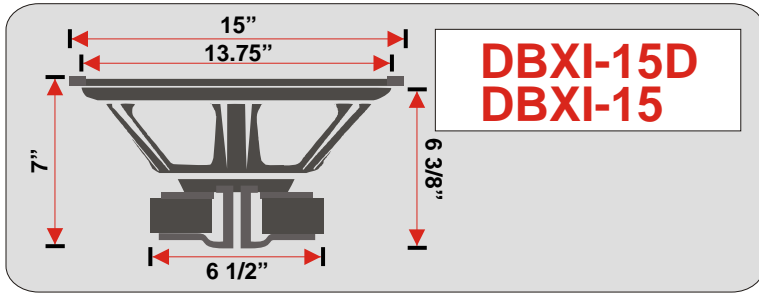

Dimensions shown are external .75" MDF.

DBXI-15/15D

#1 Bass head design for competition
Ported box Recommendation: 3.5-4.2cu.ft.

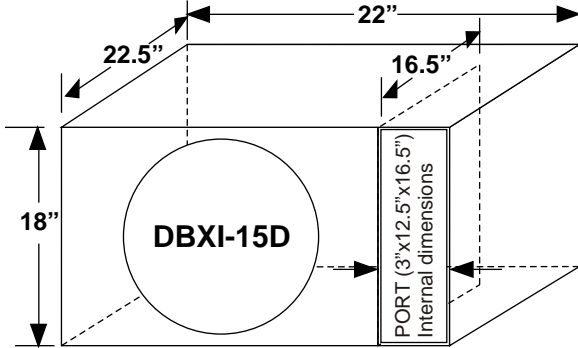

#2 Port tuned design for deep bass
Ported box Recommendation: 2.2-2.5cu.ft.

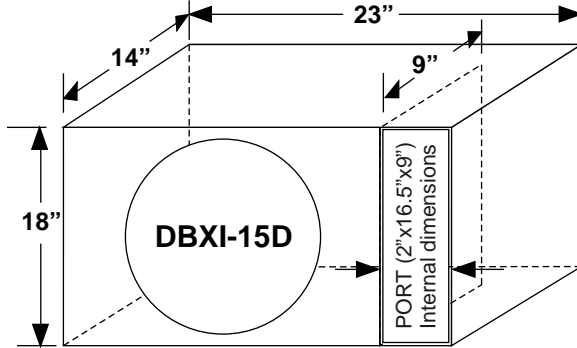

#3 Sealed design for tight bass
Sealed box Recommendation: 2.0-2.5cu.ft.

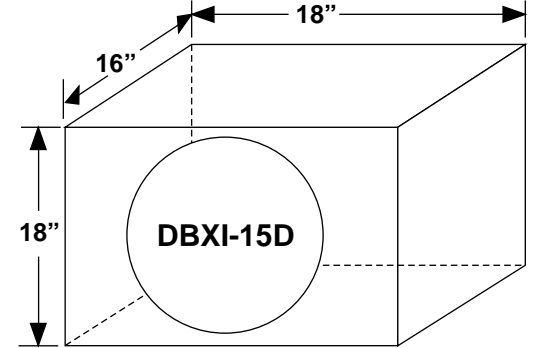

#4 Passive tuned design for deep bass small volume

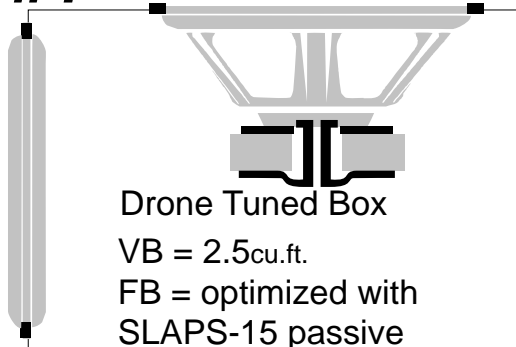

Specifications are subject to change without notice.

Earthquake, DBXI

Dear Valued Customer,

Earthquake Sound Corporation, located in Hayward California at the heart of the San Francisco Bay Area; specializes in manufacturing high end car audio products ranging from the smallest titanium tweeter to the world's largest amplifier. In its dedication to excellence, Earthquake has maintained extensive programs in research and development to provide you with the highest quality mobile audio products.

This owners manual is designed to better acquaint you with Earthquake products and to guide you through all phases of system design and application. It is imperative that you read this manual in its entirety. Earthquake technicians and staff are looking forward to answering any questions you might have.

CAUTION: Earthquake's DBXI subwoofers are capable of generating high sound pressure levels. You should exercise caution when operating our subwoofers and amplifiers. Long term exposures to high levels of sound pressure will cause permanent hearing damage. Sound pressure levels exceeding 85dB can be dangerous with constant exposure. Earthquake Sound Corporation does not assume liability for damages resulting from the direct use of DBXI or other Earthquake products, and urges users to play sound systems at moderate listening levels for every day use.

DBXI DUAL & VOICE COIL SUBWOOFER SPECIFICATIONS

DRIVER:	DBXI-10	DBXI-10D	DBXI-12	DBXI-12D	DBXI-15	DBXI-15D
Free Air Resonance (Fs)	28 Hz	27 Hz	25 Hz	24 Hz	21 Hz	20 Hz
Electrical "Q" (Qes)	0.497	0.497	0.45	0.45	1.13	1.14
Mechanical "Q" (Qms)	8.458	8.458	4.70	4.70	5.98	5.99
Total Speaker "Q" (Qts)	0.52	0.5	.5	.5	.45	.45
Xmax	3" / 76.2mm	3" / 76.2mm	3.5" / 88.9mm	3.5" / 88.9mm	3.5" / 88.9mm	3.5" / 88.9mm
Efficiency (1W/1M)	85 dB SPL	85 dB SPL	87 dB SPL	87 dB SPL	88 dB SPL	88 dB SPL
REVC	5.2 Ohm	5.2 Ohm	4.8 Ohm	4.8 Ohm	4.0 Ohm	4.0 Ohm
BL	17.6TM	17.6TM	19.6TM	19.6TM	26.8TM	26.8TM
VAS	21.9 Lit / .773 ft ³	21.9 Lit / .773 ft ³	46.4 Lit / 1.639 ft ³	46.4 Lit / 1.639 ft ³	91.1 Lit / 3.217 ft ³	91.1 Lit / 3.217 ft ³
Nominal Impedance	4-Ohm	Dual 4-Ohm	4-Ohm	Dual 4-Ohm	4-Ohm	Dual 4-Ohm
Recommended Power	400 WRMS 1000 Watts MAX	400 WRMS 1000 Watts MAX	500 WRMS 1500 Watts MAX	500 WRMS 1500 Watts MAX	750 WRMS 2000 Watts MAX	750 WRMS 2000 Watts MAX

CAUTION: Earthquake's DBXI subwoofers are capable of generating high sound pressure levels. You should exercise caution when operating our subwoofers and amplifiers. Long term exposures to high levels of sound pressure will cause permanent hearing damage. Sound pressure levels exceeding 85dB can be dangerous with constant exposure. Earthquake Sound Corporation does not assume liability for damages resulting from the direct use of DBXI or other Earthquake products , and urges users to play sound systems at moderate listening levels for every day use.

