

INTRODUCTION TO HoLeeS-15

Congratulations and thank you for trusting in us and acquiring the new HoLeeS Competition subwoofer, another incredible subwoofer from the mind and soul of Mr. Joseph Sahyoun (President of Earthquake Sound). "I really worked very hard on this driver for several years now, and wanted to perfect every aspect of the driver before it was released." "This sub is constructed from the finest parts on the planet; and I mean it." When it comes to the surround, much attention to detail is required to accommodate the huge amount of excursion and pressure that will be applied. The surround uses Poly-ether Draw, the strongest and longest lasting material available. When the driver is in a long excursion situation, you will not start to see any deformations or dimples unless the speaker is being pushed to it's absolute max peak. Unlike many subwoofers, HoLeeS's surround will not deteriorate after a few years of hard-core pounding; the surround has a working life span of 10 years plus. This wide surround will easily outlast any other and its many qualities make it the widest, longest lasting and most reliable surround, period. The driver is constructed with a unique triangular bridge type design. The voice coil pushes on the flat piston, not the cone. The cone is used for assembly purposes only. HoLeeS's cone is connected to the flat diaphragm and its lattice structure in the middle, creating the triangular system that removes cone distortion caused by wobbles, found in typical speaker designs. Earthquake's HoLeeS

uses a voice coil that is built with an aluminum bobbin and military-grade flat surface wire. The voice coil is over 3" in winding height and diameter which makes it one of the most respected drivers for producing high excursion, not only does it move a lot when you press on it, it has the electrical force necessary to move it the distance of the actual voice coil. During movement, this driver pulls less current from your amp than any other speaker on the market. Since it is designed and optimized to have a higher impedance during working periods (reactive impedance), it never goes into compression and to do so it would have to move double what is out there. The "PSP" terminal (patent pending) allows the users to have their speaker in 2-ohm, dual 4-ohm or 8-ohm.

As you can see this terminal and the rest of the speaker are the first of their kind and we are extremely proud to be the brains behind them. Earthquake Sound is a reputable manufacturer of high-end home and mobile audio products for nearly 20 years. You will notice that the engineers and other parties involved with the production of these fine subs covered a lot of ground making sure that every user is satisfied and educated as much as possible. If there is anything that you do not understand, or need help with or if you have comments please feel free to contact us at (800) 576-7944; once again for your support and we appreciate you bor email to techsupport@earthquakesound.com. Thank your business.

Recommended Power For One Subwoofer

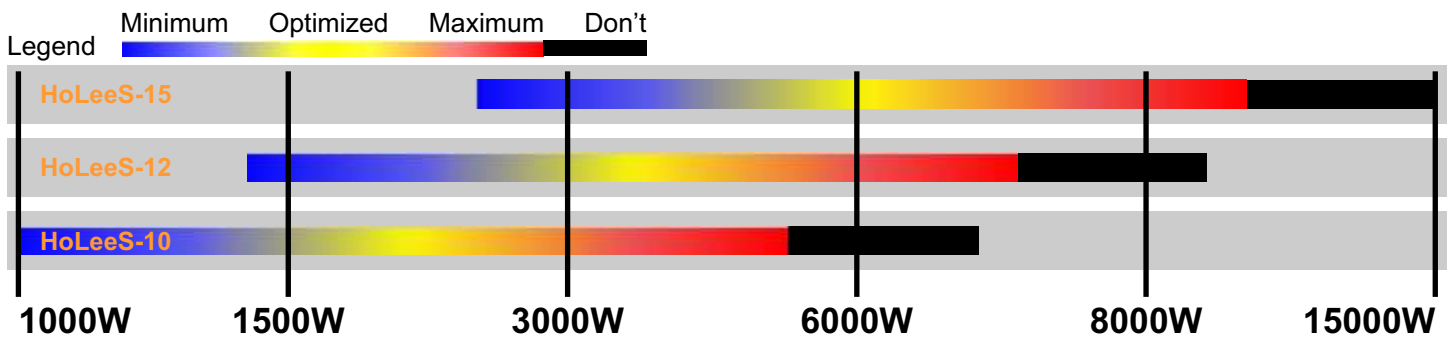

Blue (Minimum):
If you are powering your sub in this range, it will operate comfortably with zero strain or fatigue. Power ranges this low will not damage your speaker, but it wont capture the Subzero full capabilities.

Yellow (Optimized):
This zone represents the best compromise between long-term reliability, high-output and low-distortion. If you are operating your subwoofer in this range you are taking advantage of the best low distortion and sound quality that the Subzero is capable of delivering between the recommended power.

Red (Maximum):
In this zone low-distortion and sound quality become compromised. A small amount of SPL can be gained in this zone, but only a couple of dB. Remember that the more you travel out of the recommended power range the greater the chances of failure and warranty rejection. Be wise and use extreme caution and care with your speakers.

Black (DON'T):
In this zone the chances of failure are almost inevitable. When exposed to excessive heat and/ or mechanical stress the driver will loose sound quality, SPL and could seriously damage the driver or you vehicle.
SUBWOOFERS OPERATED IN THIS ZONE WILL NOT BE COVERED BY WARRANTY.

NEW TECHNOLOGIES

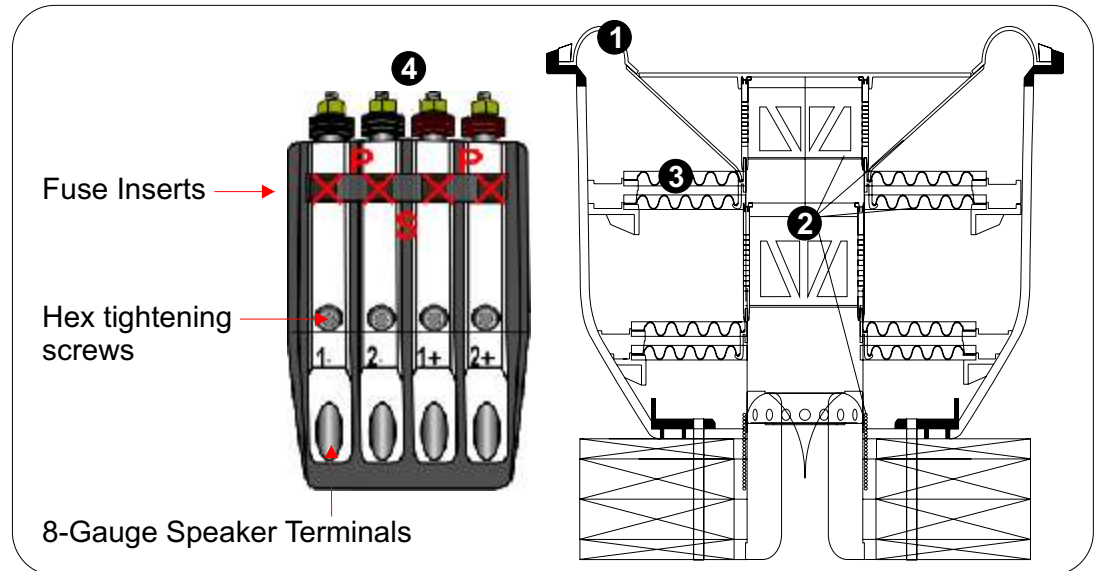

The HoleeS's are all about improving the moving parts design of a speaker. Current speaker designs suffer from several compromising parts that play a major role in producing a high level of distortions. A huge trend that many designers follow is to increase the excursion of the driver for a couple of added dB. This may be a good temporary band-aid, but they still lack compatible parts for the type of excursion that is being dealt with. If you increase the excursion you need strong, reliable and better engineered parts to do the job. If this is not done (which it usually isn't), then the speaker will be weak and will have a high level of deformation, non-linearity and distortion. The HoleeS's design blocks these bad but common traits from passing on and supports better over all bass reproduction and sound quality.

1) - Wide Polyether Surround

Earthquake's Super Wide Edge Surround allows the driver to utilize all of working parts and maximize piston area to the full potential eventually resulting in more SPL and overall better sound quality.

2) - Triangular Lattice

This invention includes all of the moving parts of the speakers. These parts which include the V.C., cone, dust-cap, surround, bridge and spiders are connected to each other and reinforced at the joints. This design helps eliminate wobbles and offsets usually caused by, non-linear spiders, V.C.s and other factory offset parts.

3) - Spider Ring

The HoLeeS spider is centered and pressed between two specially designed rings that keep the spider linear at all times and improve suspension life.

4) - PSP Terminal (Patent Pending)

The "PSP" terminal may be one of the most unique features on the HoLeeS. This terminal is stylish and is extremely easy to use. When directions are followed any level of installer can quickly have their amplifier hooked up quickly. The PSP terminal allows users to easily wire their speaker according to their amplifiers specs.



READ

To prevent serious damage or injury call Earthquake Tech-support before powering up the HoLeeS subwoofer. If the subwoofer is not wired correctly and a malfunction occurs, the damage may void the warranty. So please help us help you, and give us a call toll free. Tech-Support: 800•576•7944



Driver Specifications

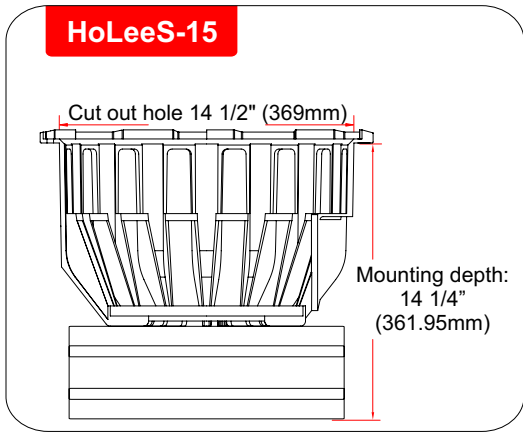

Net Weight: 112 lbs	Qts: 0.352
Revc: 2.000ohm	No: 0.295%
Levc: 6.363mH	SPLo: 86.7dB
Fo: 23.581Hz	Vas: 3.117CuFt
Sd: 89.000msqM	Cms: 78.468uM/N
BL: 21.285TM	Mms: 580.5293g
Qms: 4.846	Mmd: 565.262g
Qes: 0.380	Max Power: 15,000 Watts
	RMS Power: 7,000 Watts

Application / Box Design SPL Burping

8Ft.		Tune @ 65Hz
7Ft.		Tune @ 65Hz
6Ft.		Tune @ 65Hz
5Ft.		Tune @ 65Hz
4Ft.		Tune @ 65Hz

Sound Quality

For an SQ box use the same dimensions as the DBDrag design below, but use these port dimensions.

Port tuned @ 43Hz

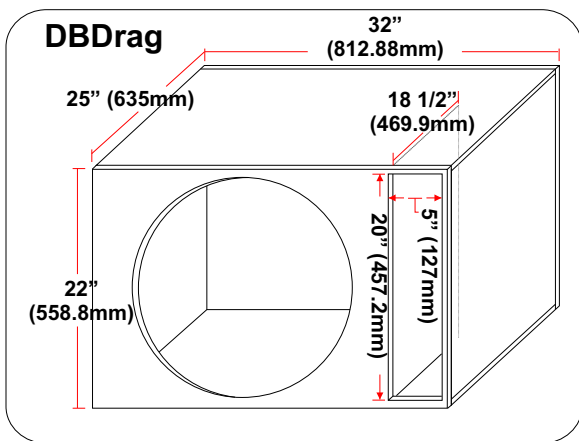

Outer volume: 6-10 cubic feet
Port surface: 107.25 sq. inch
Port length: 18 1/2" (469.9mm) typically wraps around
Wall thickness: 1" (25.4mm)
Front baffle: 2" (50.8mm)

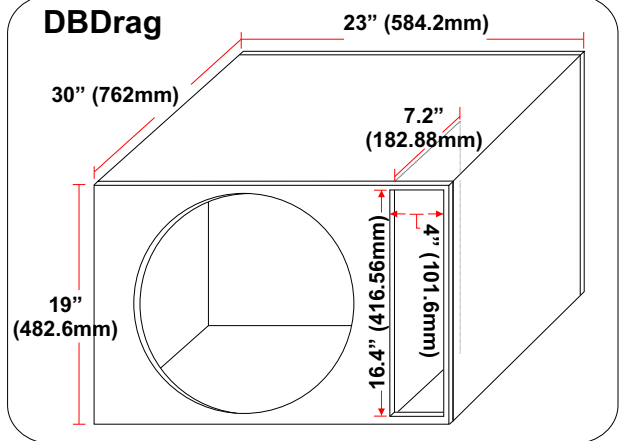

Outer volume: 7.587 cubic feet
Inner volume: 5.4 cubic feet • Tuned @ 70Hz
Port surface: 65.6sq. inch
Port length: 7.2" (182.88mm)
Wall thickness: 1" (25.4mm)
Front baffle: 2" (50.8mm)

Port length may vary depending on frequency
 Specifications are subject to change without notice.

Wiring Configurations

The Ho-Lee-S subwoofer comes equipped with 2 voice coils (dual 1 ohm), it can be used in .5 or 2 ohm configurations. The terminal comes equipped with fused jumpers, please note that center terminals are not operational. (you must use both terminals)



Please Read Carfully

1-CHANNEL 1-OHM LOAD

(voice coils in parallel)
(No Fuses)

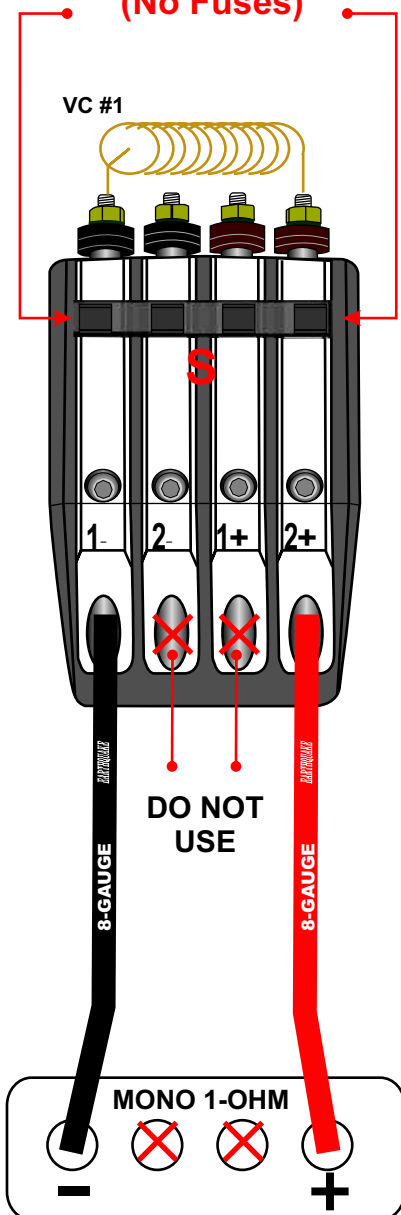

1-CHANNEL 1-OHM LOAD

(voice coils in parallel)
(No Fuses)

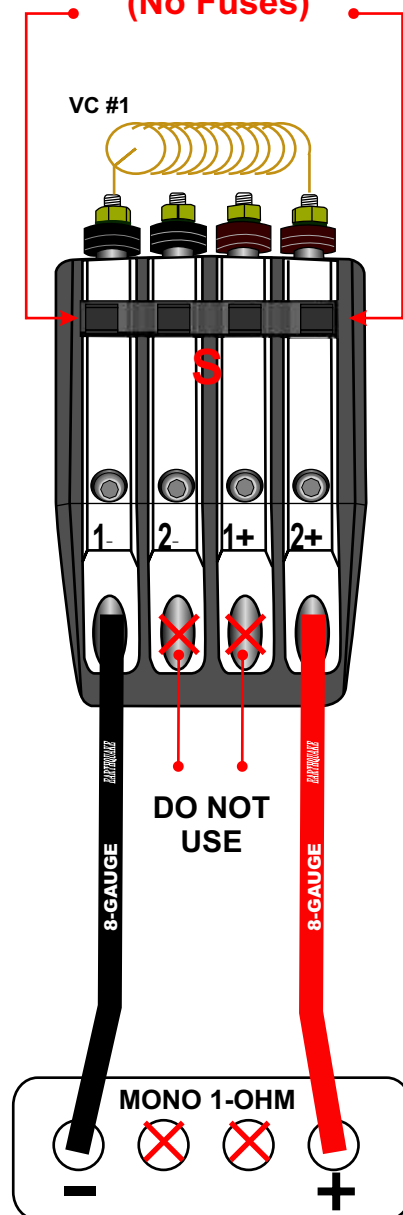

Parallel
1/2 Ohm

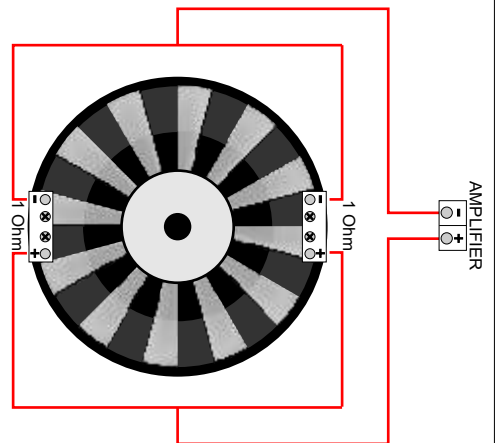

Series
2 Ohm

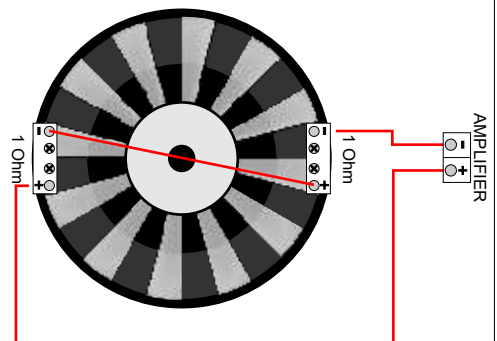

Normal

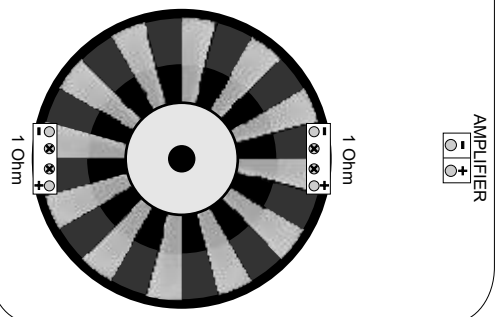

AMPLIFIER TERMINAL