

SUBZERO-15 2500 WATTS

Winner of the 2004
Design & Engineering Award
INNOVATIONS
INTERNATIONAL CES



REVC = 7.90 Ohm
LEVC = 2.47 mH
Fo = 22.6 Hz
Sd = 74.06 msqM
BL = 15.24 TM

Qms = 4.921
Qes = 1.21
Qts = 0.88
SPLo = 89.7dB
No = 0.088%

Vas = 113 Ltr
Mechanical Xmax = 4" peak to peak
Electrical Xmax = 2" peak to peak
Cms = 187.13 uM/N
Mms = 252.65g
Mmd = 241.60g

1" = 2.54 cm
1 cubic foot = 1728 cubic inches
Grille Clearance: 2"
Displacement: .3 Cube Feet

#1 Sealed design for tight bass

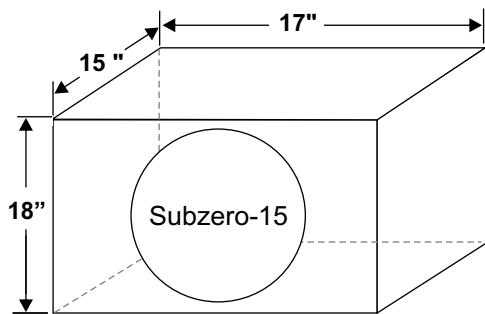

Outer dimension shown using 3/4" thick MDF.

#2 Passive tuned design for deep bass small volume

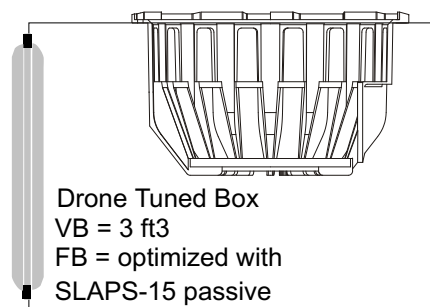

Outer dimension shown using 3/4" thick MDF.

#3 Ported design

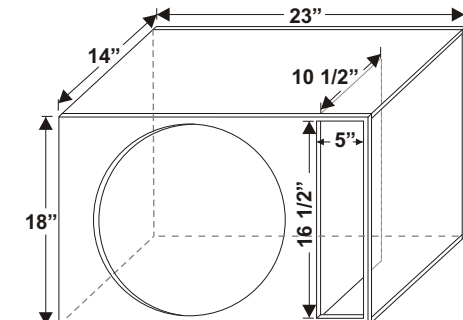

Outer dimension shown using 3/4" thick MDF

#4 Bass head design for competition

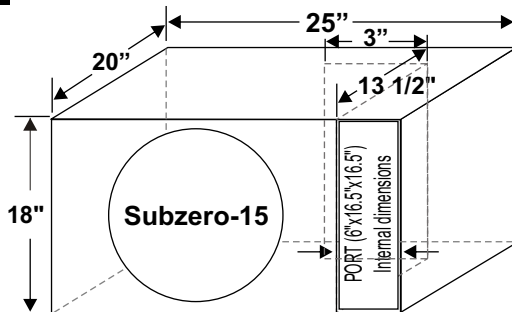

Outer dimension shown using 3/4" thick MDF.

FOR 44Hz Tuning: Port length equals 26"
FOR 60Hz Tuning: Port length equals 16 1/2"

SUBZERO-15

Cut out hole 369mm / 14 1/2"

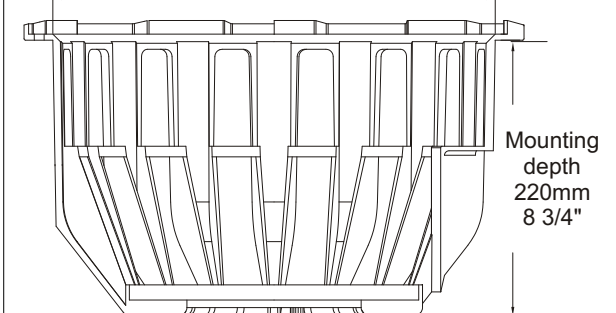

HOW TO WIRE / FUSE YOUR SUBZERO TO AN AMPLIFIER

PSP (Parallel Series Parallel) Terminal

The Subzero subwoofer comes equipped with 2 voice coils (dual 2x4 ohms), it can be used in 2, 4 and 8 ohm configurations. The terminal comes equipped with fused jumpers, the voice coil can be easily configured in series or in parallel to match the amplifier in use. It is just a simple flip of a fuse, here's how it works.

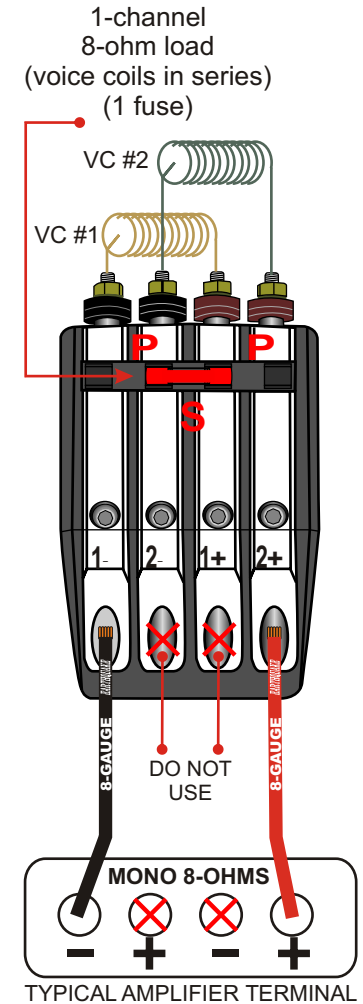
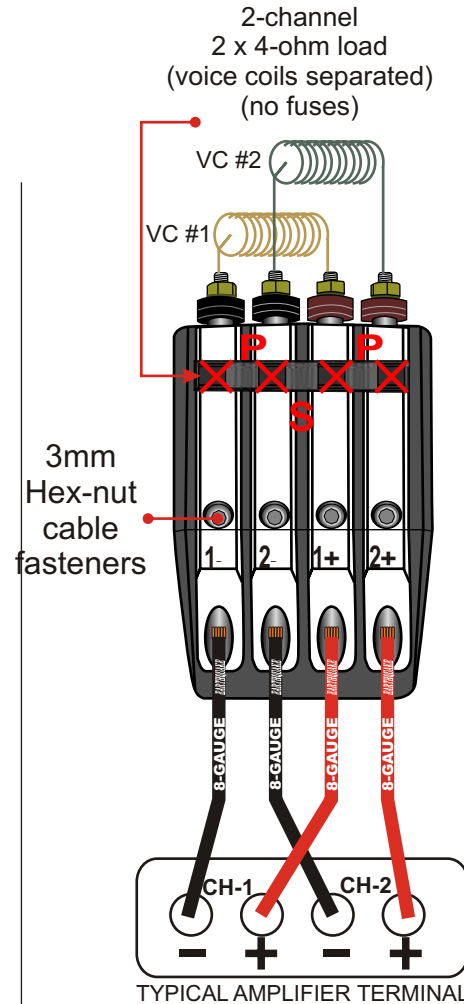
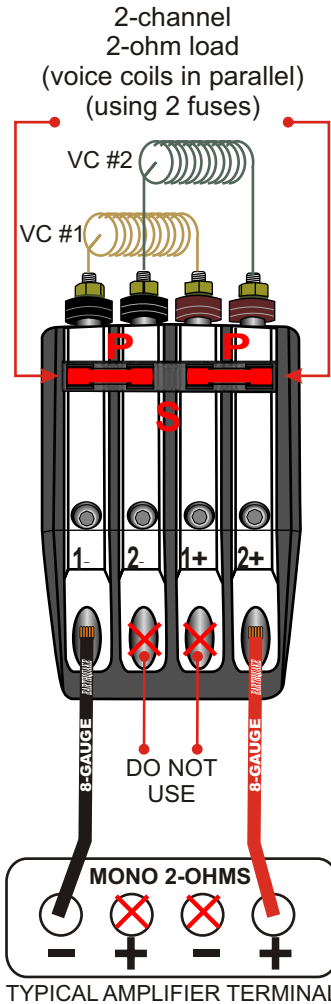

The diagram -on the left side- shows the PSP terminal in a 2-ohm parallel configuration (both voice coils are connected in parallel). Simply place the 2 fuses in the outer positions in the fuse placement area. Insert the negative speaker wire to the far left insert and one positive to the far right insert.

This diagram shows the PSP terminal in a 4-ohm configuration (the two voice coils are separated). No fuses are used in this configuration, the voice coils are powered up separately.

The diagram - on the right side- displays the PSP in an 8-ohm mode. You will notice that there is only one fuse in the center of the fuse placement area. The voice coils are wired in series. Insert the negative speaker wire to the far left insert and one positive to the far right insert.