

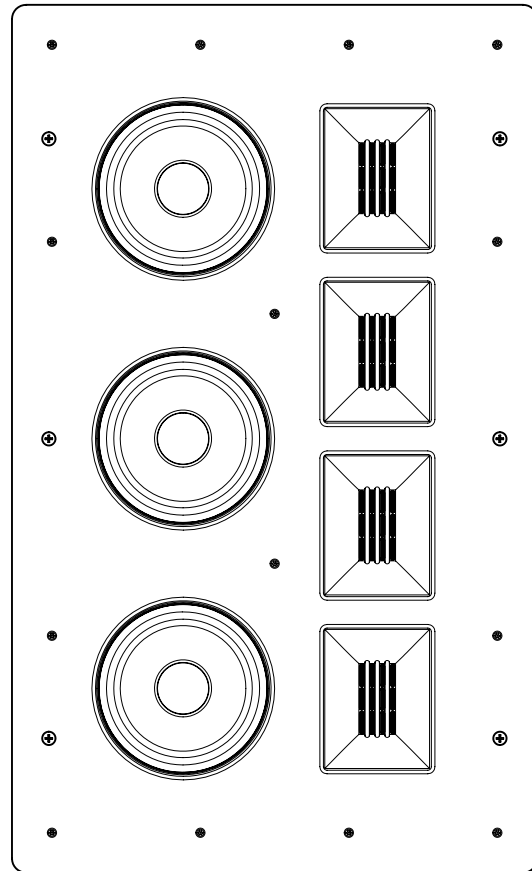

The Sound That Will Move You

Cinénova Clarté

In-Wall & On-Wall
LCR Speaker

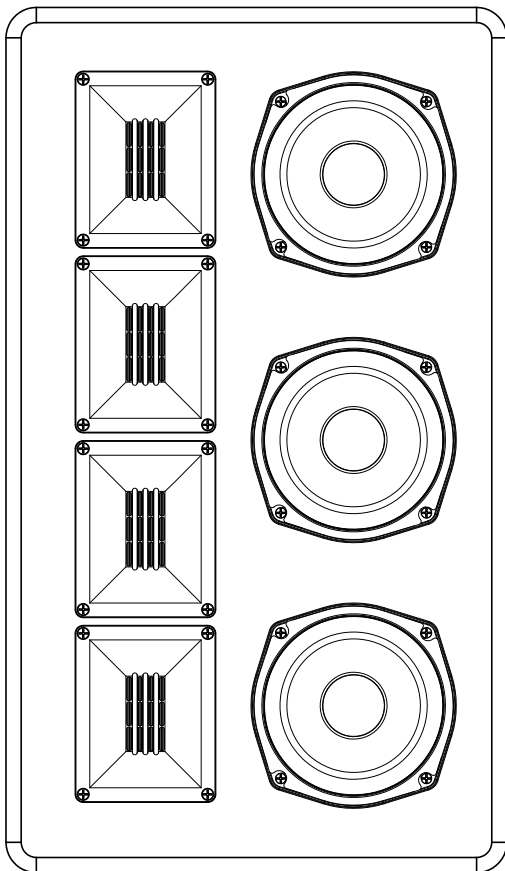

Earthquake Sound Corp.
(510) 732-1000 | U.S. Toll Free: (800) 576-7944
www.earthquakesound.com

Table of Contents

Introduction.....	3
In-Wall Overview.....	4
On-Wall Overview.....	5
In-Wall Specifications.....	6
On-Wall Specifications.....	7
Home Theater Setup.....	8
Speaker Placement.....	9
In-Wall Installation.....	10
On-Wall Installation.....	11
Warranty Guidelines.....	12
Notes.....	13-14

Earthquake Sound Corporation
2727 McCone Avenue Hayward,
CA 94545. USA
Tel: 510-732-1000
Fax: 510-732-1095



© 2026 Earthquake Sound Corporation. All rights reserved.

This document should not be construed as a commitment on the part of Earthquake Sound Corporation. The information is subject to change without notice. Earthquake Sound Corporation assumes no responsibility for errors that may appear within this document.

Introduction

The Cinénova Clarté on-wall and in-wall LCR are Earthquake's newest addition to the infamous Cinenova family of high fidelity products. The Clarté was designed to be mounted vertically or horizontally allowing it to be positioned for left, right, and center channels. This offers plenty of flexibility whether you are installing them for new or pre-existing home audio setups. Both the on-wall and in-wall Clarté speakers feature a combination of three 5.25" carbon fiber cone woofers for distortion-free bass and four 2" ultra-fast ribbon tweeters for remarkable sound quality with pinpoint accuracy. With Earthquake's Cinénova Clarté LCR, you will hear more details in music and movies with elegant sound reproduction and tonal balance.

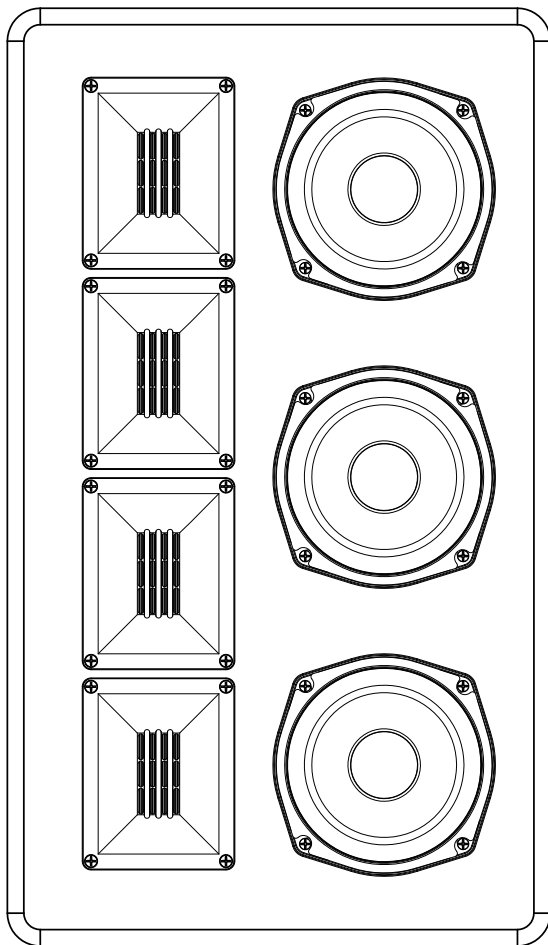

On-Wall

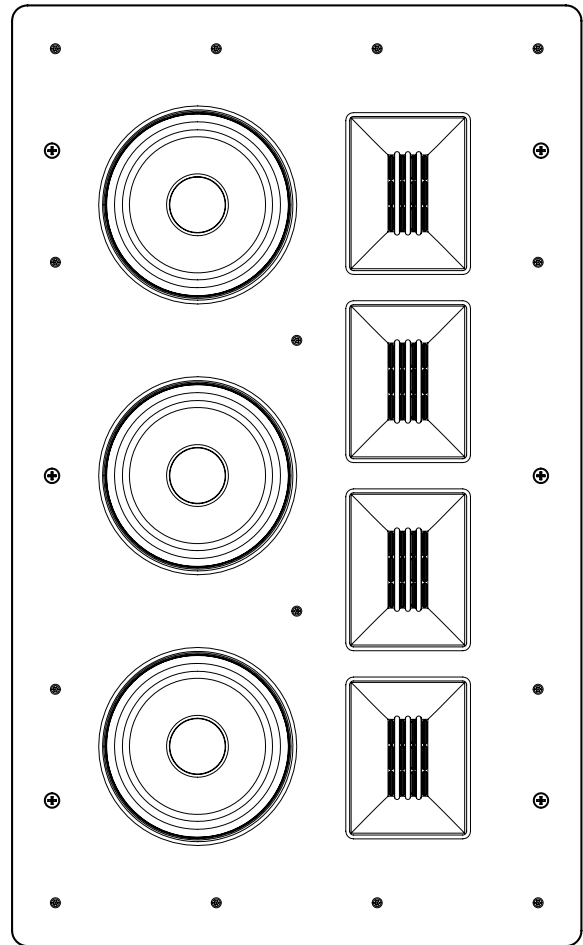

In-Wall

In-Wall Overview

1. 5.25" carbon fiber cone woofers
2. 2" ribbon tweeters
3. Gold plated spring loaded terminals
4. Cross style mounting bracket
5. Center wiring groove
6. Wall/cabinet bushing
7. Turn-N-Lock™ mechanism (x6)
8. Turn-N-Lock screw (x6)

In The Box:

- 1 Cinénova Clarté In-Wall LCR Speaker
- 1 Removable Grille
- 1 Installation Manual

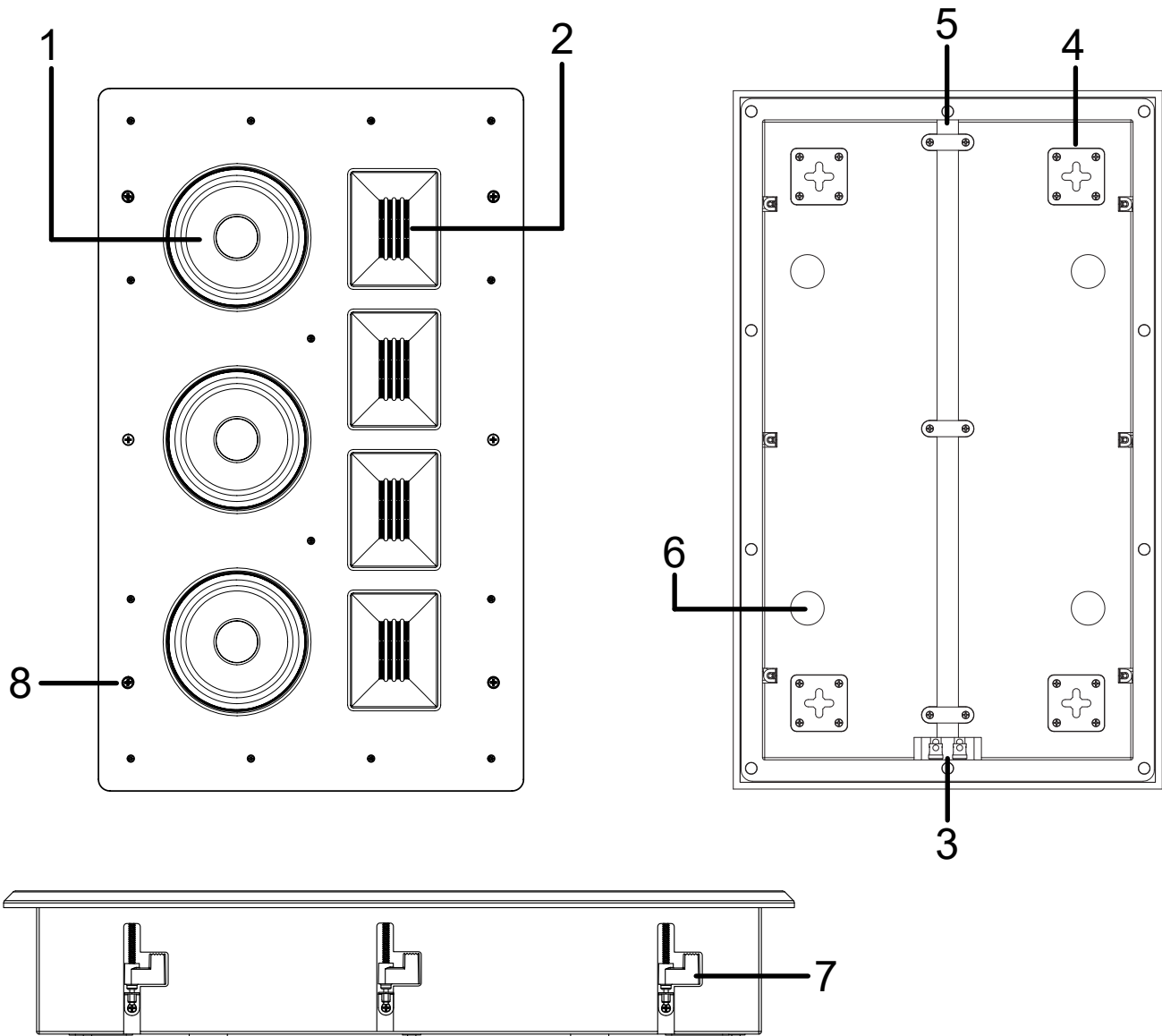

On-Wall Overview

1. 5.25" Long strand fiber woofer cone
2. 2" Ribbon tweeters
3. Gold plated spring loaded terminals
4. Cross style mounting bracket
5. Center wiring groove
6. Wall/cabinet bushing

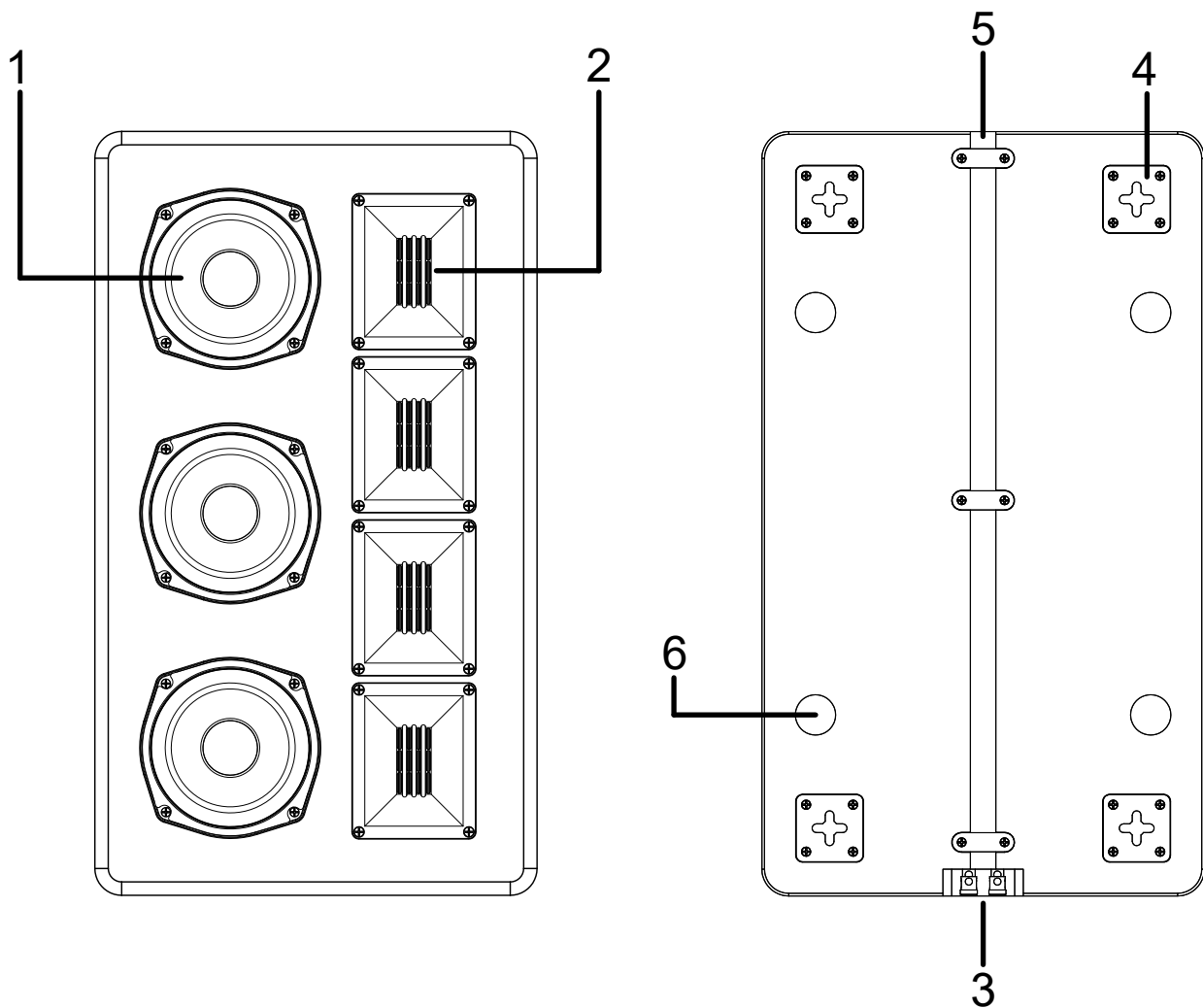

In-Wall Specifications

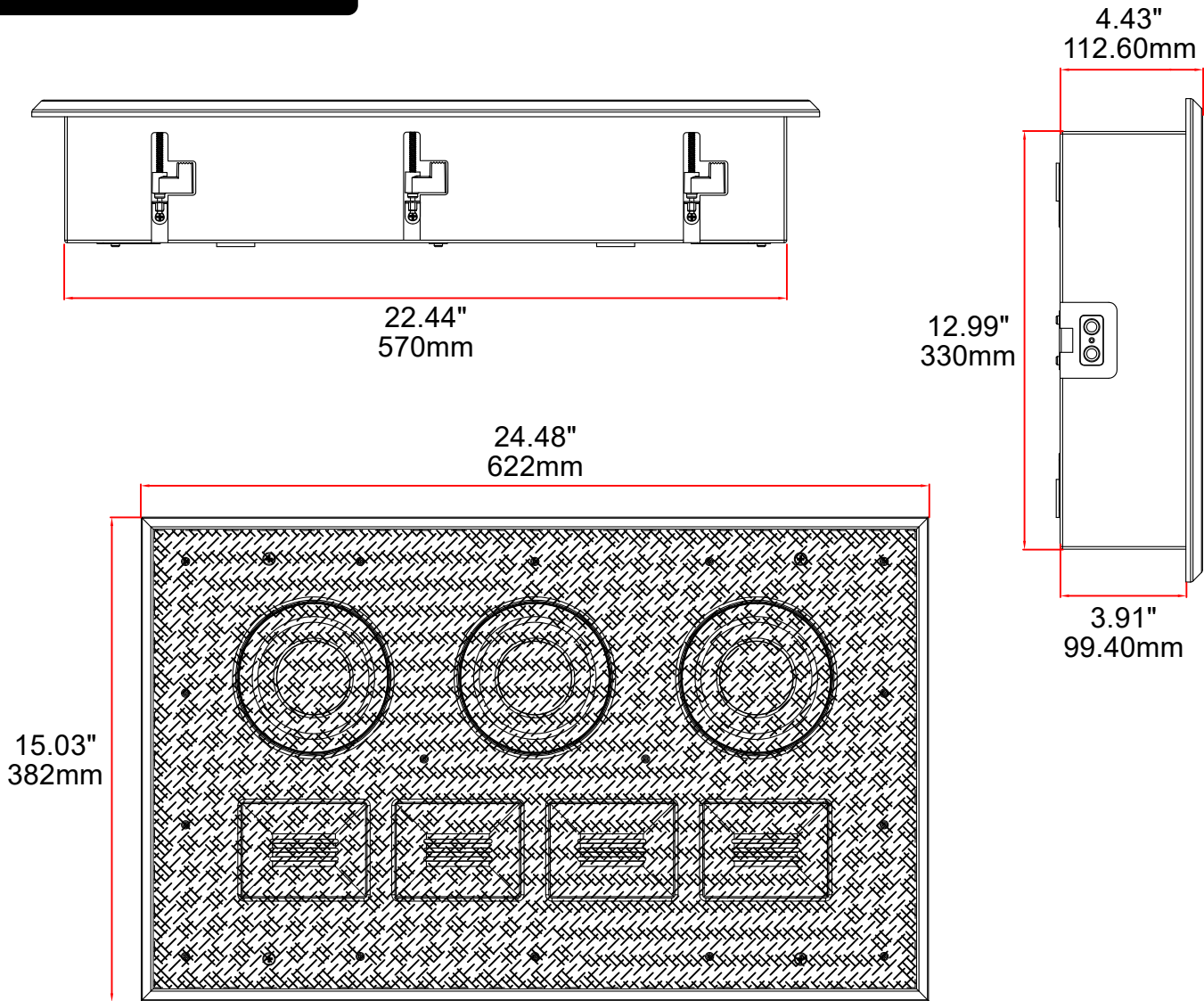

IW-C5	
Power Handling	120W RMS 600W Max
Frequency Response	55Hz–20kHz
Crossover Frequency	2000Hz LP 12dB/Oct 2000Hz HP 12dB/Oct
Coverage Angles	122° Vertical
	122° Horizontal
Impedance	8-Ohm
Sensitivity	96dB (2.83V/1m)
Weight	23.58 lb (10.70 kg)
Mounting Depth	3.91" (99.40mm)

On-Wall Specifications

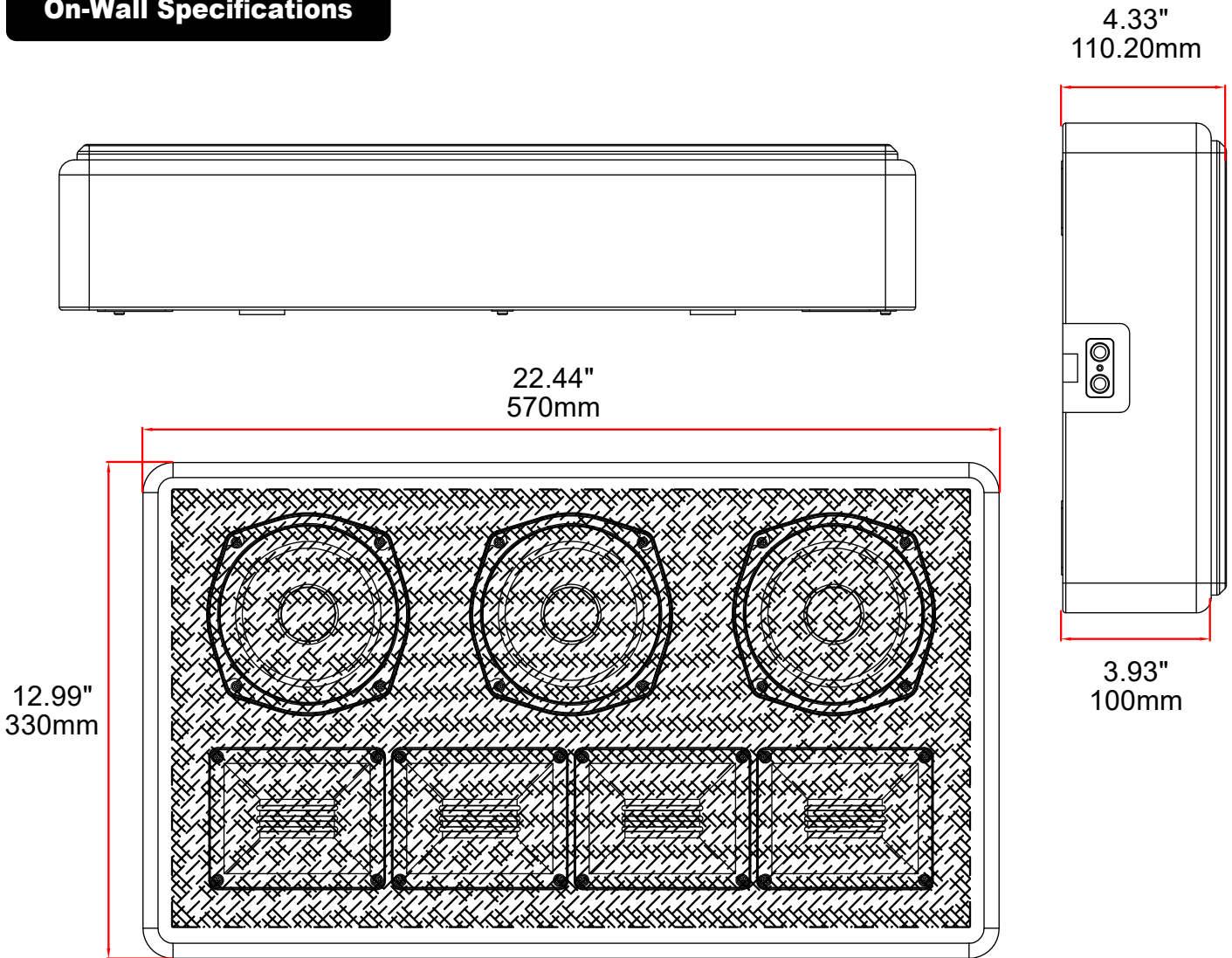

OW-C5	
Power Handling	120W RMS 600W Max
Frequency Response	55Hz–20kHz
Crossover Frequency	2000Hz LP 12dB/Oct 2000Hz HP 12dB/Oct
Coverage Angles	122° Vertical 122° Horizontal
Impedance	8-Ohm
Sensitivity	96dB (2.83V/1m)
Weight	20.95 lb (9.50 kg)

Home Theater Setup

Home Theater LCR Setup With MiniMe DSP Subwoofers

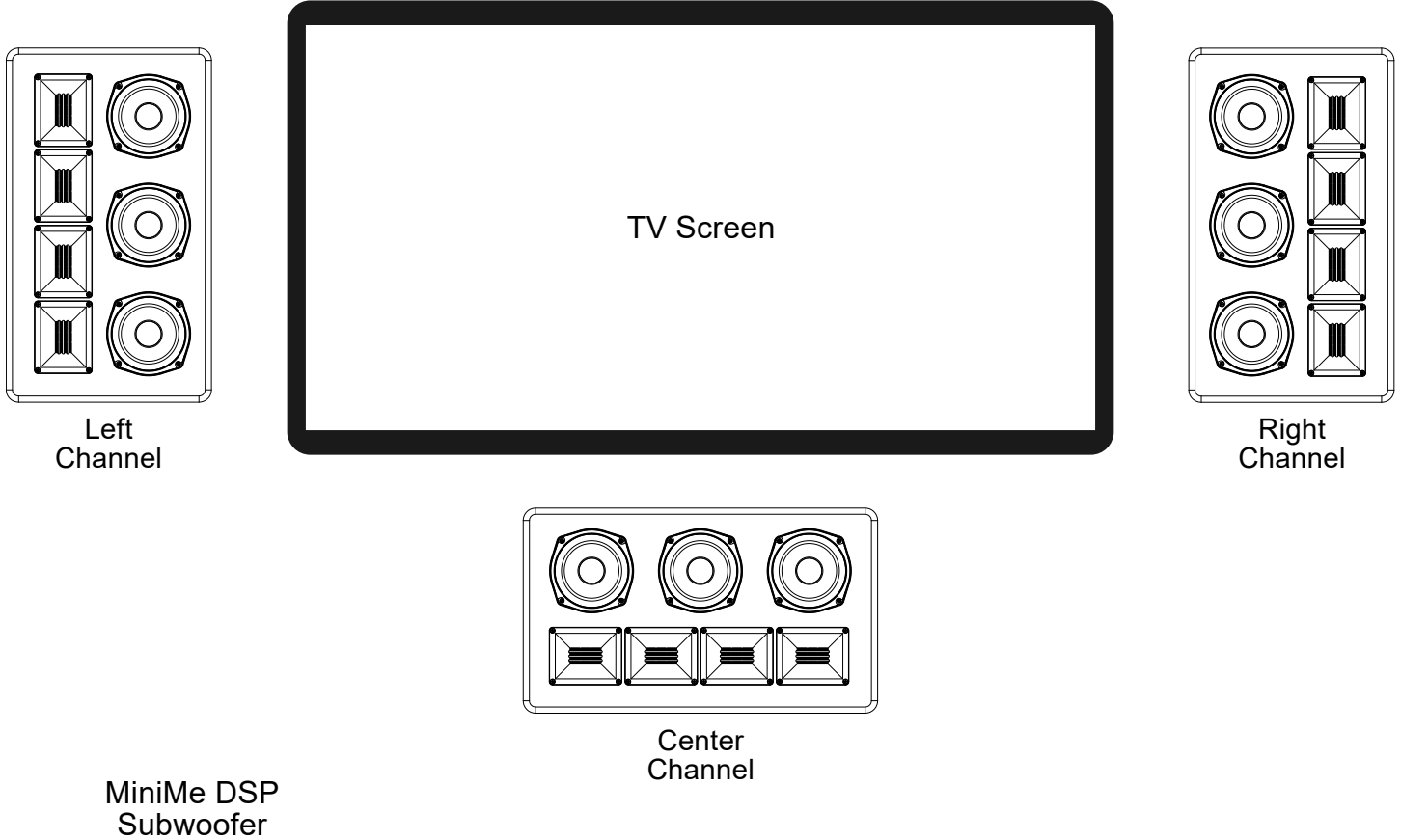

The illustration above demonstrates how the on-wall and in-wall Clarté can be positioned for a typical left, right, and center channel home theater setup. Note that the units should be positioned so that the tweeters are on the outside.

Speaker Placement

The Cinénova Clarté speakers were designed to be mounted either on or flush with the walls depending on the model. To optimize their acoustics you should follow these simple guidelines.

For the best stereo reproduction, the speakers should be placed an equal distance from your listening position and separated so that the angle between them is between 40° and 60° . The units should also be placed with the tweeters on the outside and near ear level about 3 to 4 feet from the floor. This will ensure that you receive the best possible performance from your listening position..

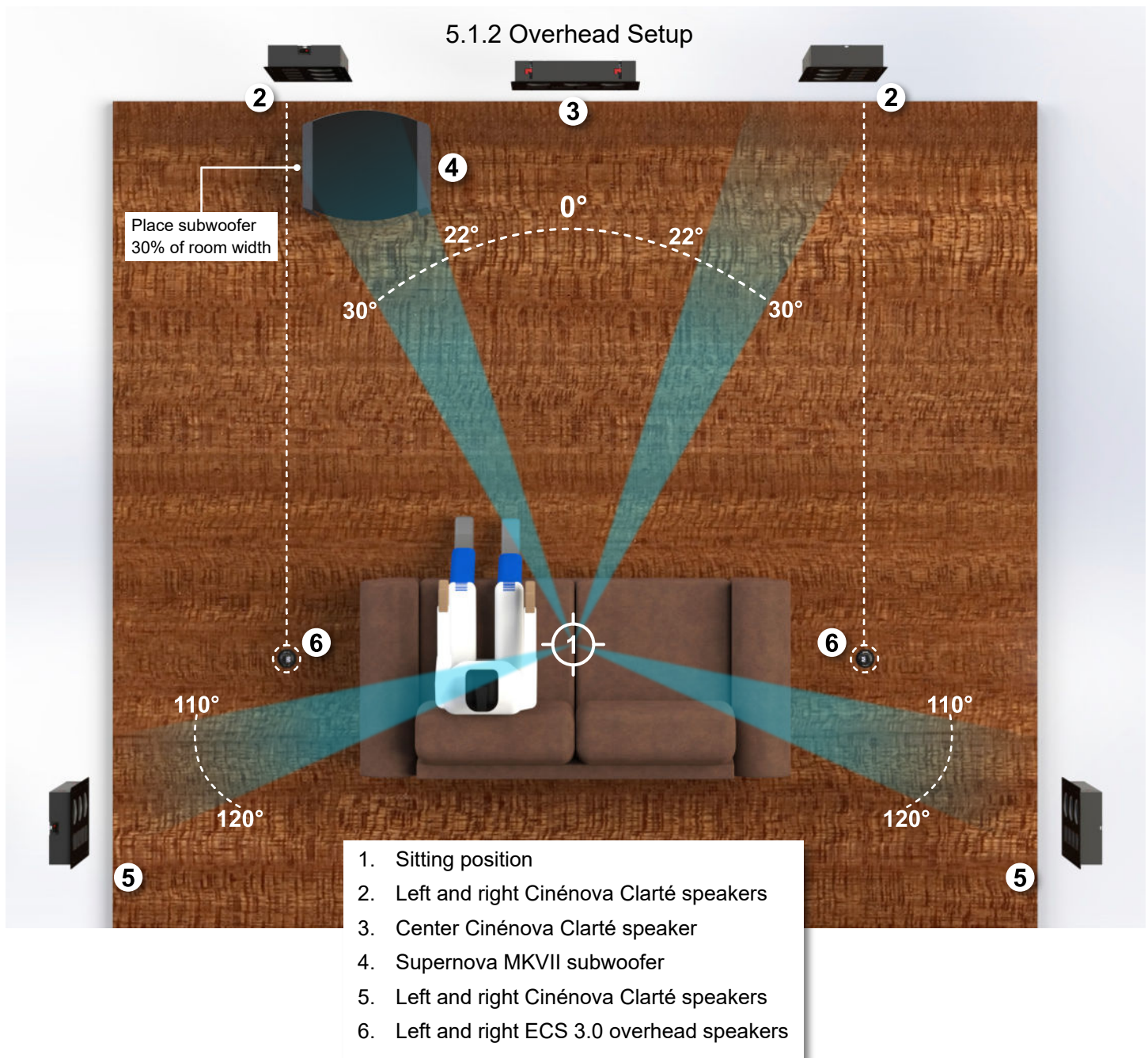

Speaker Placement Cont.

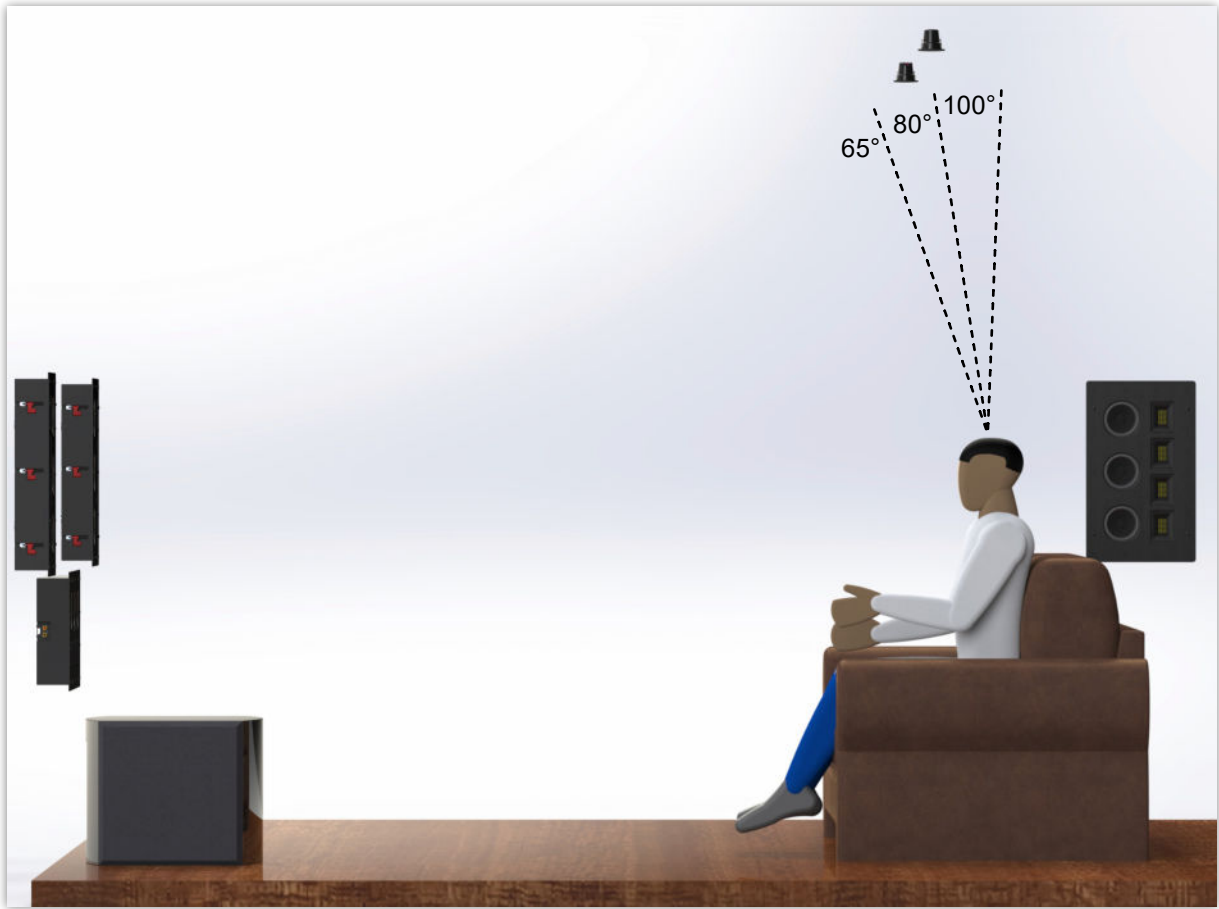

Speaker Installation (In-Wall)

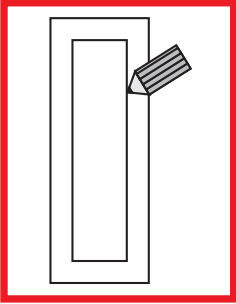

LOCATE & MARK THE WALL STUDS

Outline the cut out hole using the supplied template. Stay clear from any 2 x 4 studs.

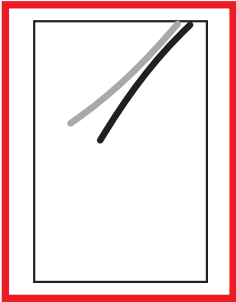

CUT THE DRYWALL

Cut out the drywall marked by the supplied template.

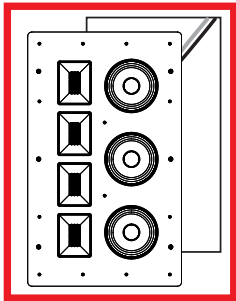

CONNECT THE SPEAKER

Attach speaker wires and insert the Clarté speaker into the drywall opening.

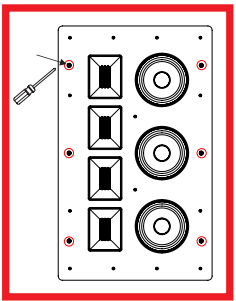

SECURE WITH TURN-N-LOCK™

Align the speaker into position. Tighten the screws evenly to secure the unit with the TURN-N-LOCK™ mechanism. Turning the screws clockwise will engage the mechanism. Keep turning the screw until the TURN-N-LOCK™ dog ear moves towards the front plate and is snug against the inside of the drywall. This will ensure that the speaker is firmly secure inside of the wall.

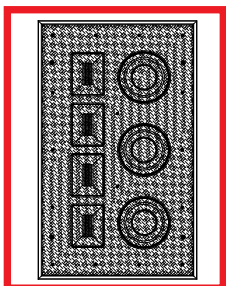

PLACE THE GRILLE

Align the speaker grille into position. The grille will magnetically attach itself to the plate.



Cut out template included

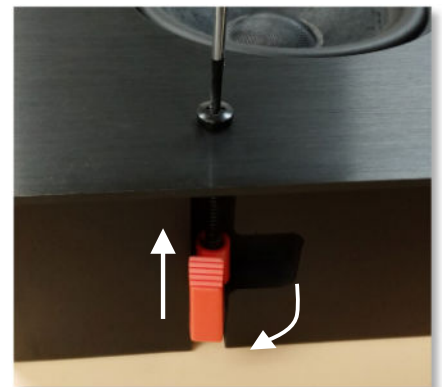
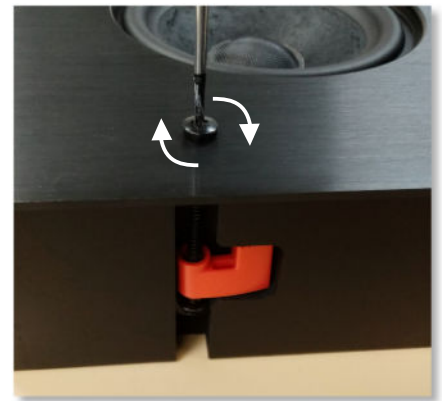

Speaker Installation (On-Wall)

Use the built-in cross mounting brackets to mount the on-wall Clarté. Because the the speaker weighs over 20 lbs; it should be mounted to either a wall stud using M4 sized screws (not included) or spring loaded toggle bolts if not mounted to a stud. The mounting hardware can be found at most local hardware stores.

Vertical Installation

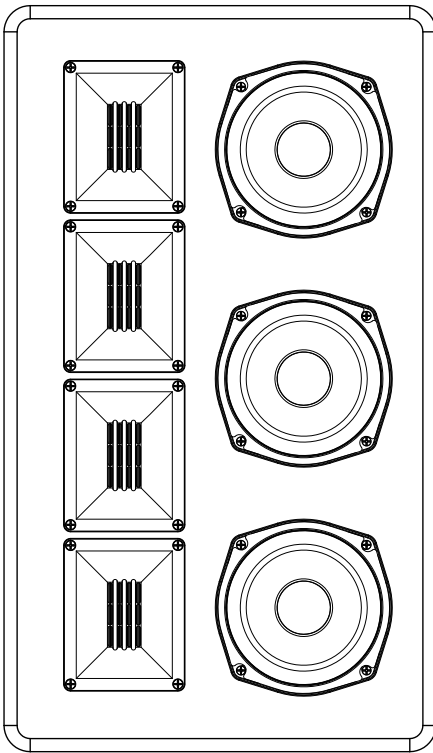

Horizontal Installation

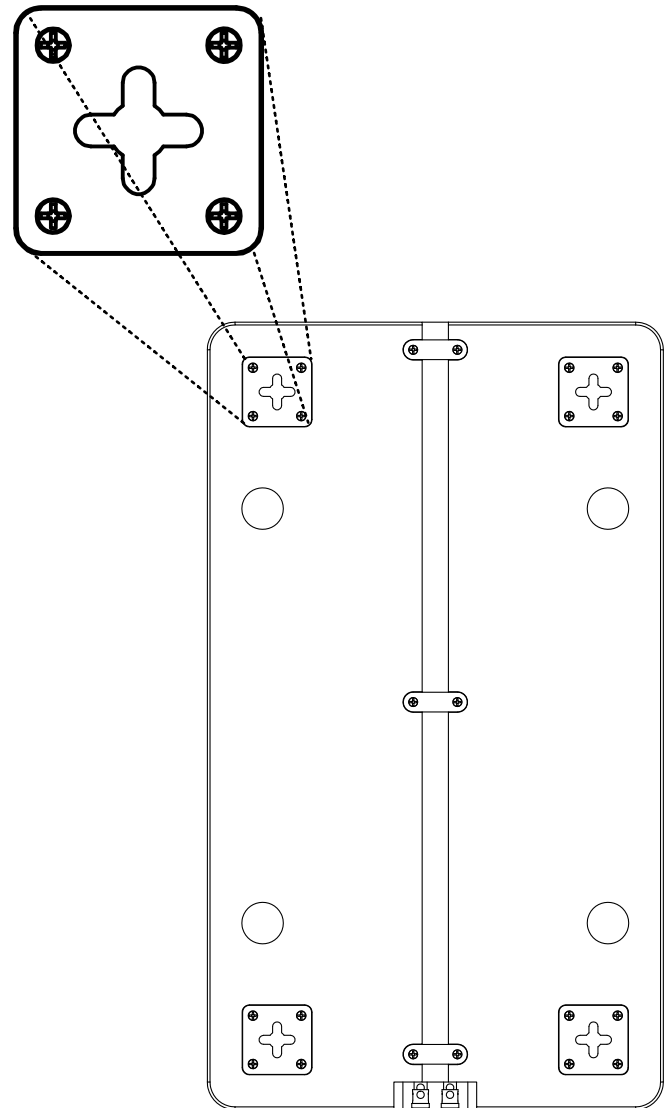
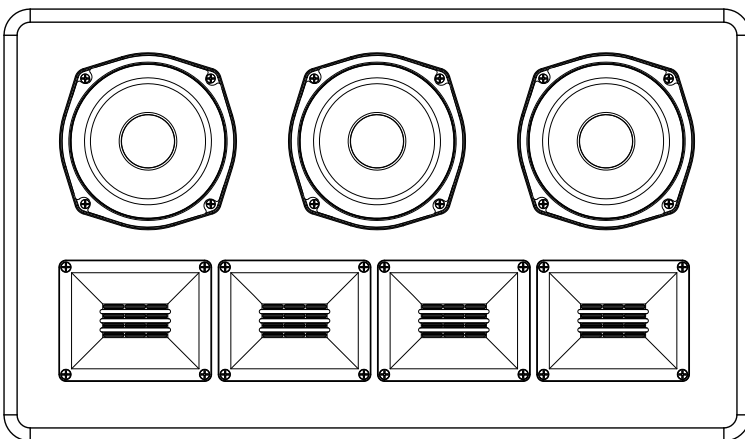

Warranty

Earthquake Sound warrants the original purchaser that all Factory Sealed New Audio products be free from defects in material and workmanship, under normal and proper use, for a period of one (1) year from the date of purchase (as shown on the original sales receipt with serial number affixed/written on it). The one (1) year warranty period is valid only if the product is properly installed by an Earthquake Sound authorized party and the warranty registration card is properly filled out and sent to Earthquake Sound Corporation. If the product is installed by a non-authorized party, a thirty (30) day warranty period applies.

(A) One (1) year limited warranty guidelines:

Earthquake pays for labor, parts and ground freight (US Mainland only) back to the customer.

(B) Warning:

Products (sent for repair) that are tested by Earthquake technicians and deemed to have no problem(s) will not be covered by the limited warranty. Customer will be charged a minimum of one (1) hour of labor (at ongoing rate) plus the shipping charges back to the customer.

(C) Earthquake agrees to repair or replace - at our discretion - all such defective products/parts subject to the following provisions:

- Defective products/parts have not been altered or repaired by other than an Earthquake factory approved technician.
- Products/parts are not subjected to negligence, misuse, improper use, or accident, damaged by improper line voltage, used with incompatible products, or have its serial number or any part of it altered, defaced or removed, or have been used in any way that is contrary to Earthquake's written instructions.

(D) Warranty Limitations:

Earthquake warranty does not cover products that have been modified or abused, including but not limited to the following:

- Damages due to misuse, abuse or use of improper cleaning materials/methods.
- Bent frame, broken connectors, holes in speaker cone, holes/cracked in wall plate, burnt parts.
- Fading, deterioration of components & finish due to improper exposure to elements.
- Burnt tracers on PCB.
- Product/part damaged due to poor packaging or abusive shipping conditions.
- Subsequent damage to other products.

A warranty claim will not be valid if the warranty registration card is not properly filled & returned to Earthquake with a copy of the sales invoice.

(E) Service Request:

To receive product(s) service, contact Earthquake Sound's service department at (510) 732-1000 or tech@earthquakesound.com and request an RMA (Return Material Authorization) number as item(s) shipped without a valid RMA number will be refused. Make sure you provide us with your complete and correct shipping address, a valid daytime phone number, and a brief description of the problem you are experiencing with the product. In most cases, our technicians might be able to resolve the problem over the phone or via e-mail, thus eliminating the need to ship the product.

(F) Shipping Instructions:

Product(s) must be packaged inside its original protective box(es) to minimize transportation damage. Shipper claims regarding items damaged in transit must be presented to carrier. Earthquake Sound Corporation reserves the right to refuse improperly packaged product(s). A copy of the original sales receipt must accompany the product(s) returned for service. Ship the product(s) to:

Earthquake Sound Corporation. 2727 McCone Avenue. Hayward, CA 94545

The customer is responsible for the cost of shipping the product(s) to Earthquake Sound Corporation

(G) Disputes Resolution:

All disputes - between clients and Earthquake Sound Corporation - resulting from the one (1) year limited warranty policy must be resolved according to the laws & regulations of the county of Alameda, California.

Notes